

Bottom rolling door frame 6' x 6'-8"

Eclipse
Folding Door Systems

Hardware / Integrated Folding Doors / Screens / Shades

Presenting a great upgrade opportunity for homeowners looking to replace their current sliding door system.

Our new bottom sill/track system combined with the proven F3 Floor-rolling systems, robust TwinPoint Gen2 Lockset and the door panels allows the traditional sliding door to be removed and new bi-folding (2) doors installed to 'double your doorway'.

Doubling your doorway improves your access and connection with the outdoor living area. It more than doubles the airflow to reduce reliance on air-conditioning and provides fresh healthy air.

- Can be installed with our award winning S2 Insect Screen. Finger-tip control makes opening and closing child's play. Fully retracts when not in use.
- Frame is provided fully machined and finished ready for the panels to be installed
- Slimline head and sill profiles work with F3 Floor-rolling hardware to remove overhead vertical load. The frame can be simply installed on existing building structures, even with limited header size.
- TwinPoint Gen2 Lock is a stylish alternative to surface mounted dropbolts. Simple to install and use, its elegant central handle operates concealed top and bottom bolts, closing doors in one easy movement.
- Optional double handles, with an outside key and interior thumbturn, provides convenient and secure exterior access.

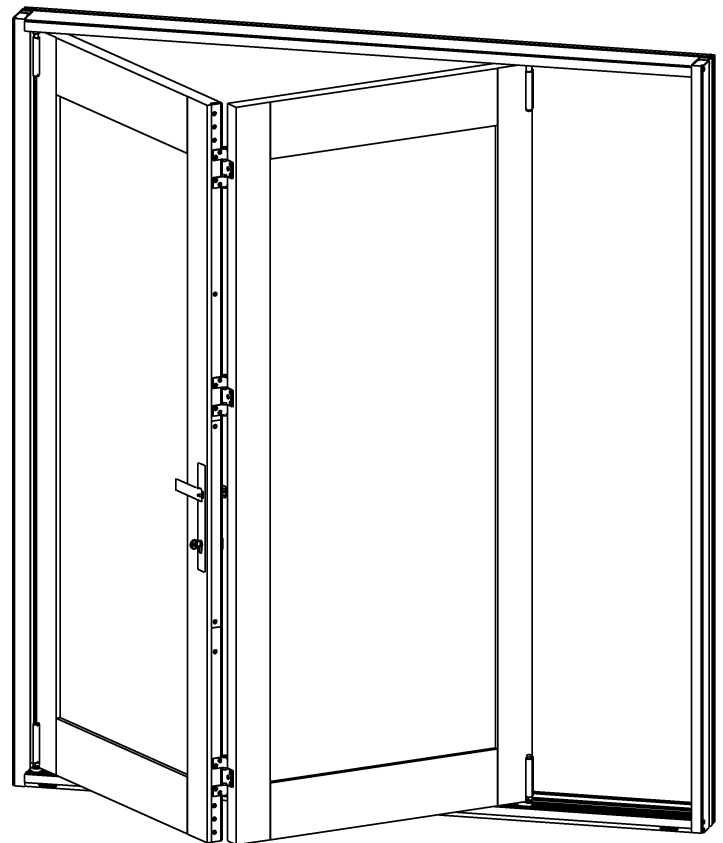

Double your doorway

Horizontal section

Frame width	71"	71 1/4"	71 1/2"	71 3/4"	72"
Panel width	33.847"	33.972"	34.097"	34.222"	34.347"
	33 13/16"	33 15/16"	34 1/16"	34 3/16"	34 5/16"

Panel width formulas

2 panels: (Frame width - 3.306") / 2

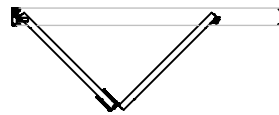
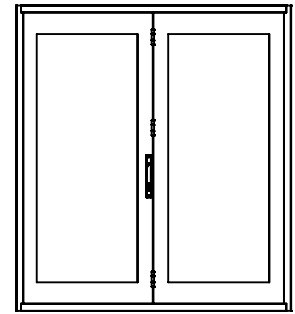
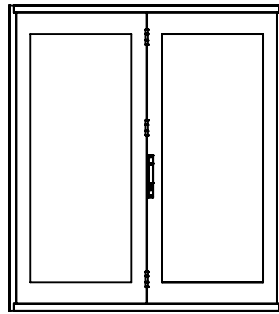

2L

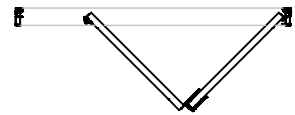

2R

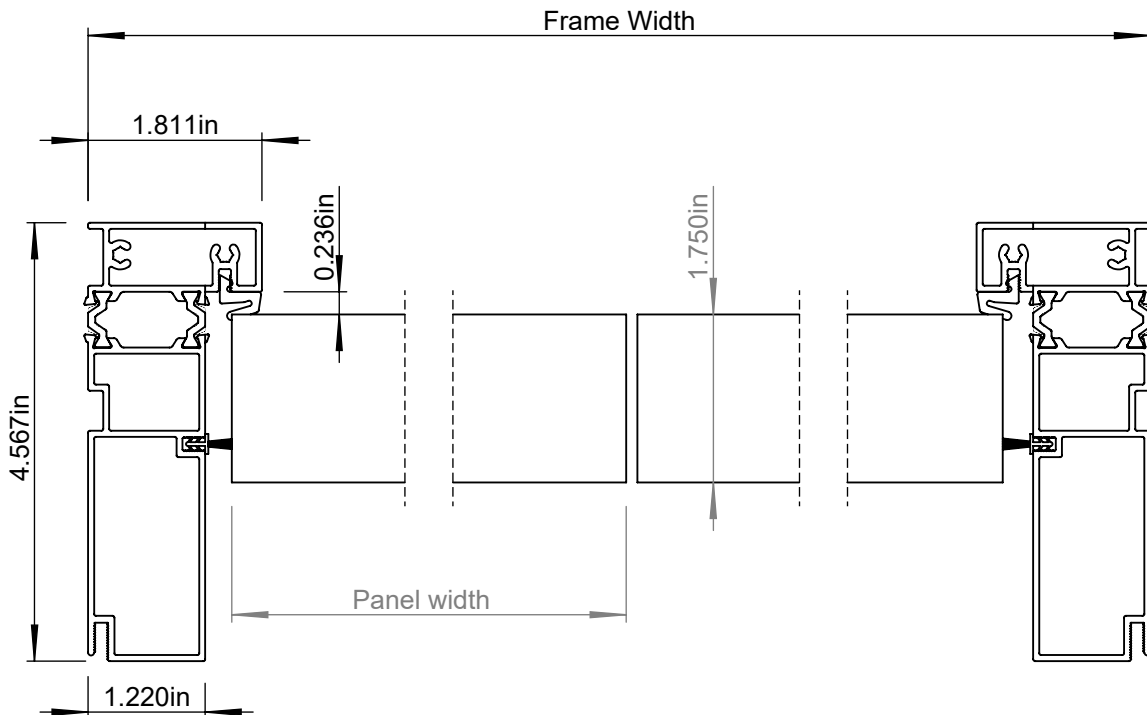

Vertical section

Frame height	79"	79 1/4"	79 1/2"	79 3/4"	80"
Panel height	75.938"	76.189"	76.439"	76.689"	76.939"
	75 15/16"	76 3/16"	76 7/16"	76 11/16"	76 15/16"

Panel height formula

All panels: Frame height - 3.062"

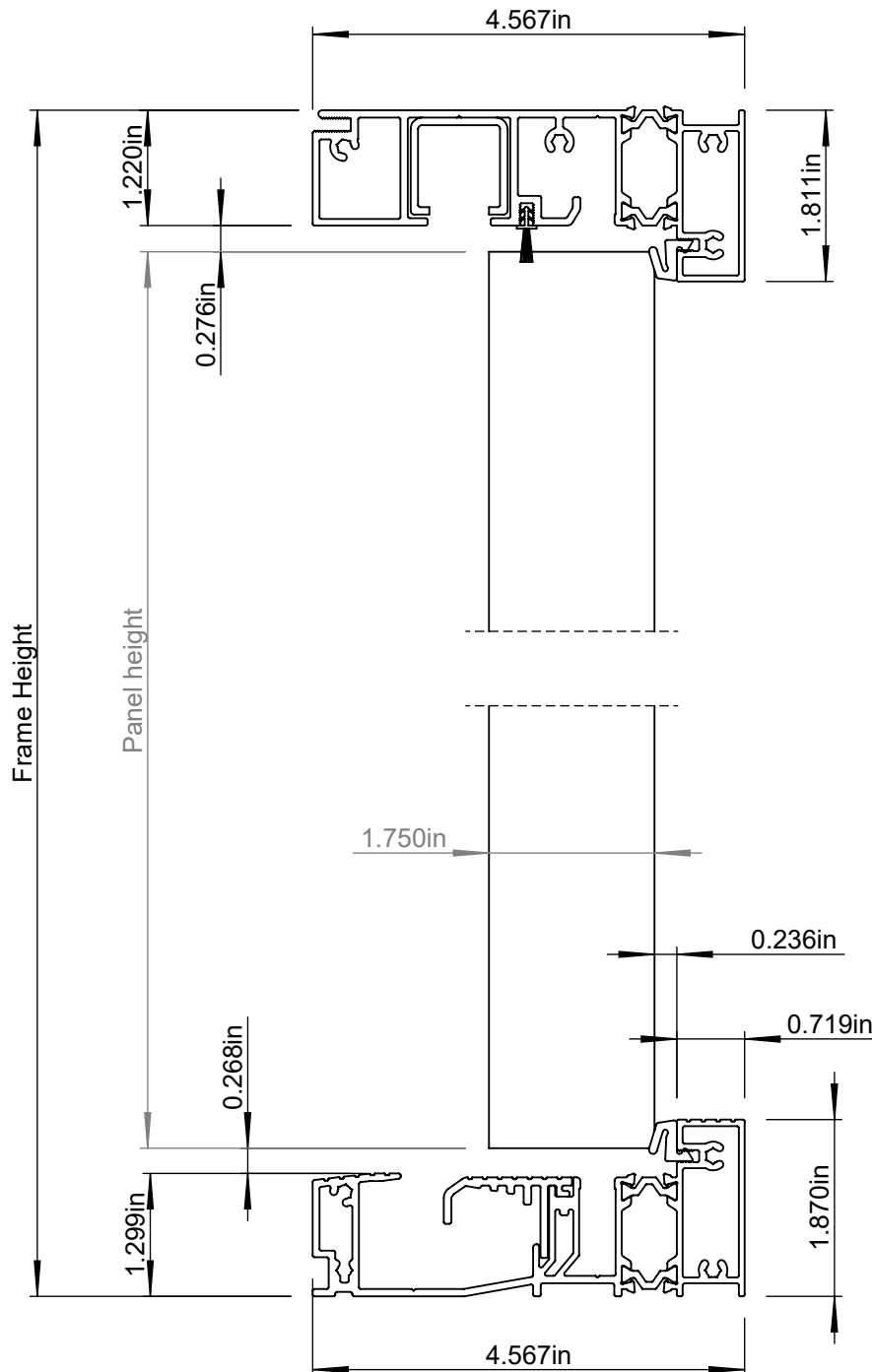

Bottom rolling door frame 6' x 6'-8"

Profiles



Folding Door Systems

Hardware / Integrated Folding Doors / Screens / Shades

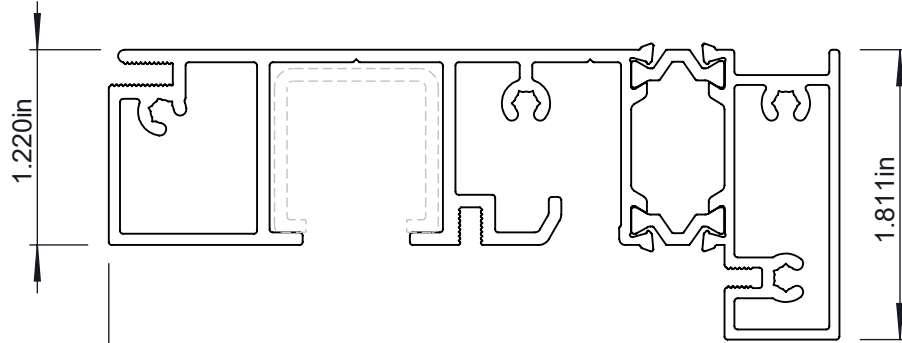

Head
Thermally broken aluminum

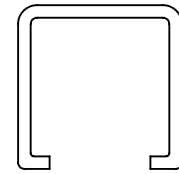

Guide track
Polyethylene

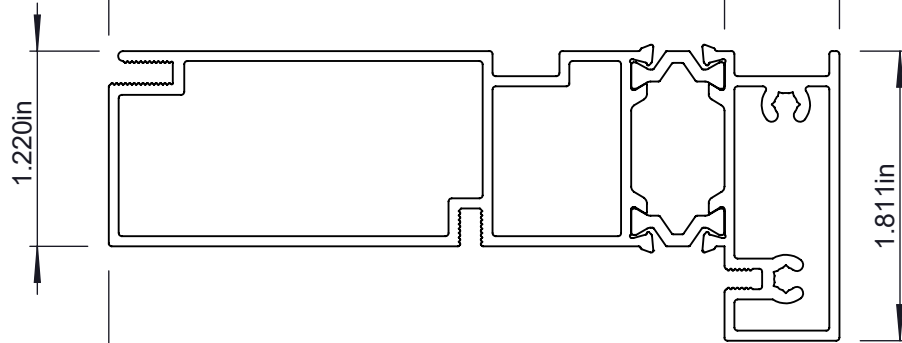

Jamb
Thermally broken aluminum

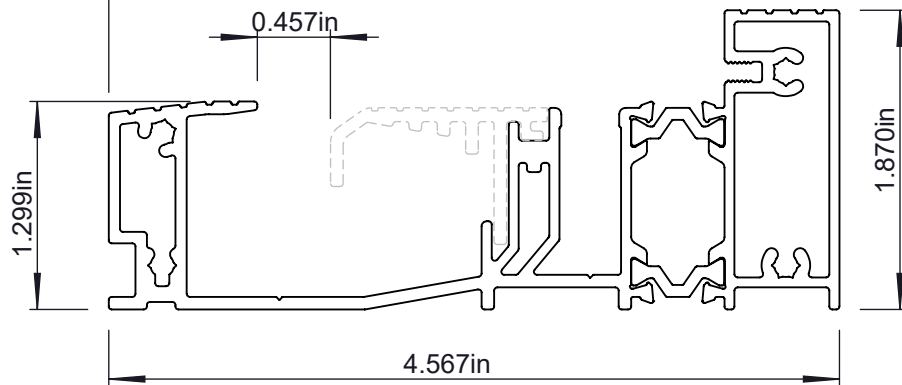

Sill
Thermally broken aluminum

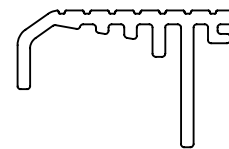

Removeable sill cover
Aluminum

Bottom rolling door frame 6' x 6'-8"

Profiles with S2 screen



Folding Door Systems

Hardware / Integrated Folding Doors / Screens / Shades

Head

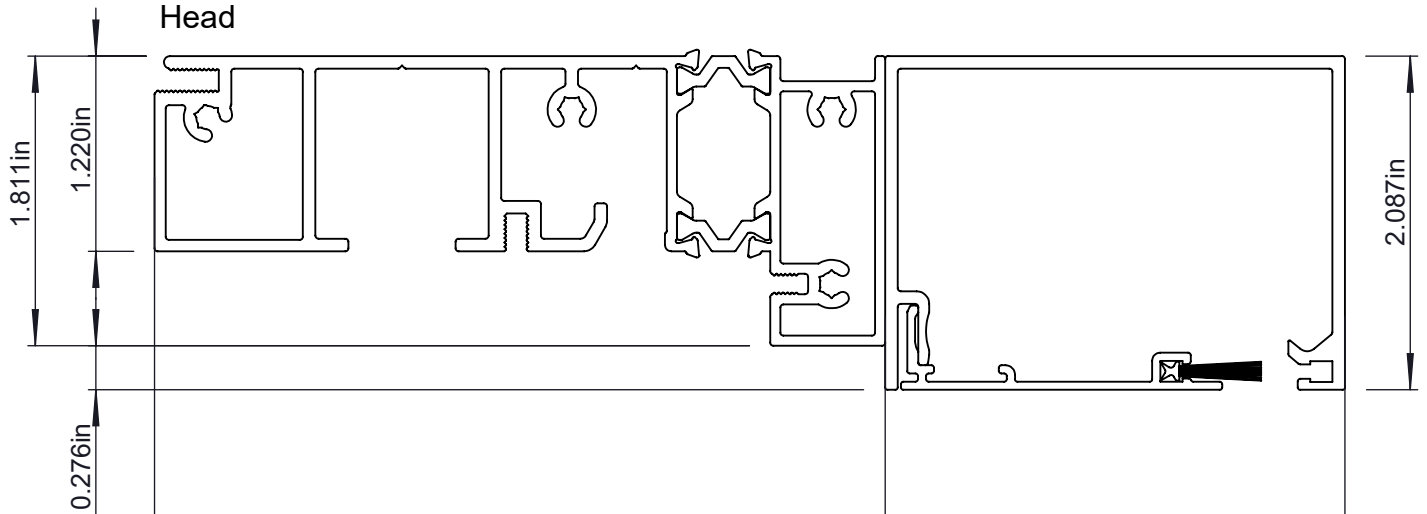

Sill with S2 on sub floor

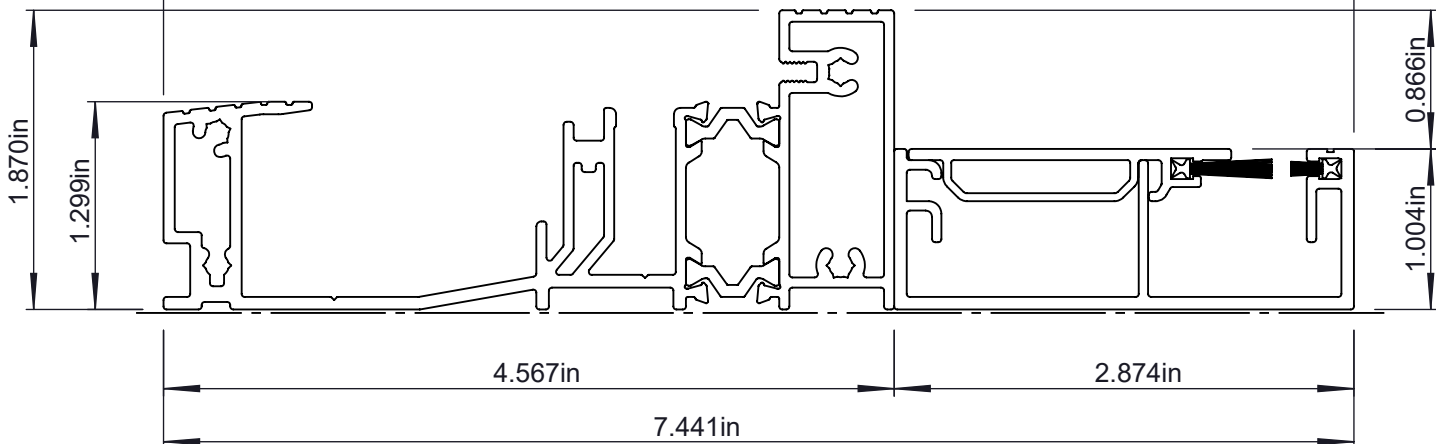

Sill with S2 on Shim on Existing Flooring

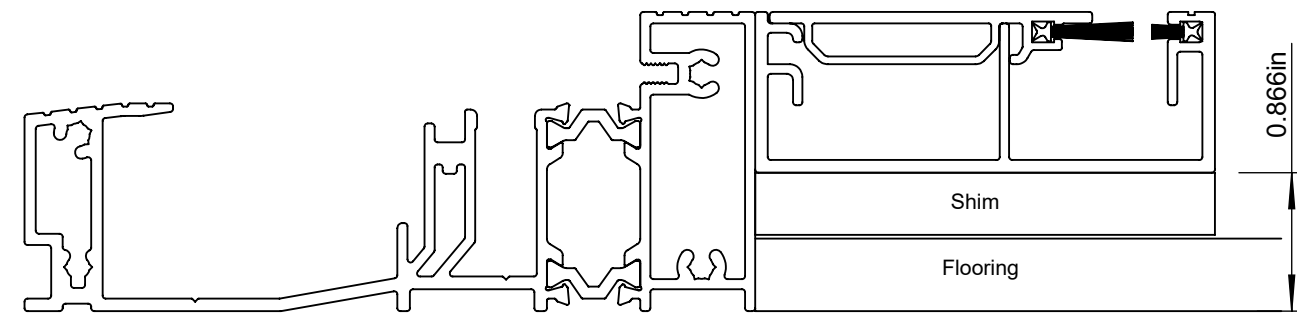

Bottom rolling door frame 6' x 6'-8"

Profiles with S2 screen

Eclipse

Folding Door Systems

Hardware / Integrated Folding Doors / Screens / Shades

Jamb

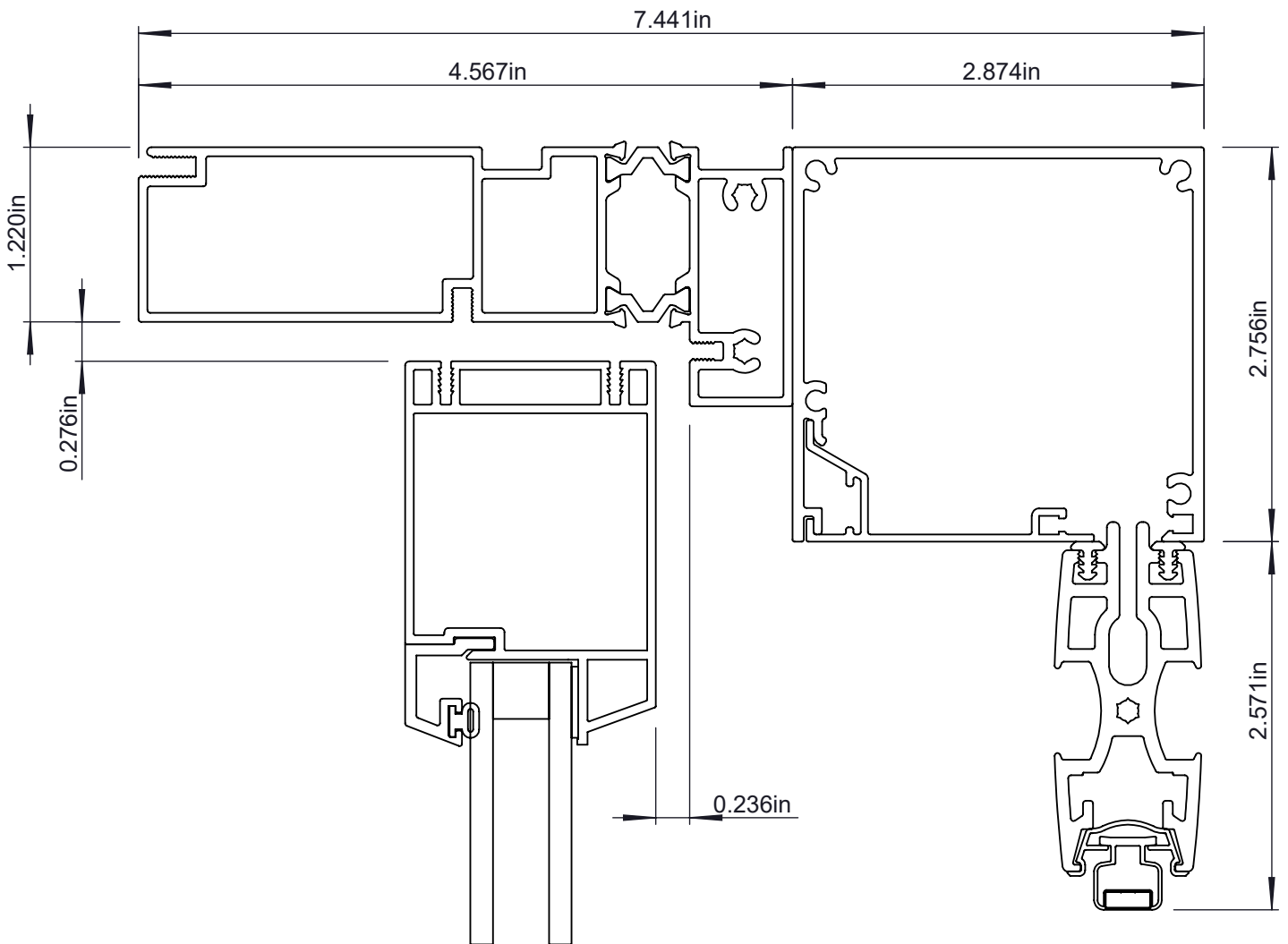

Bottom rolling door frame 6' x 6'-8"

Hardware for 2 left panels

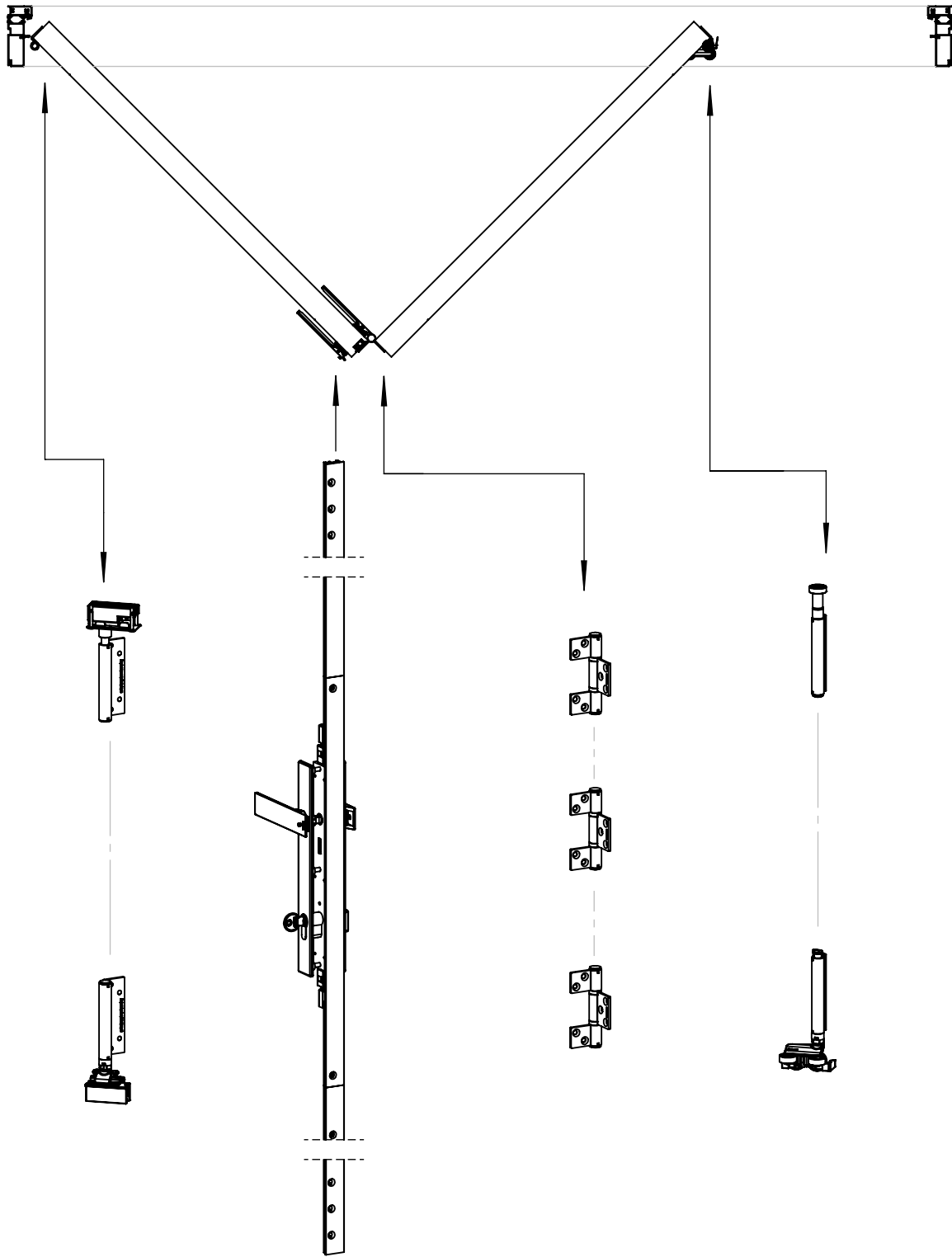

Pivot set
Left

TwinPoint Gen2
Right

Straight hinge set

End carrier set
Right

Bottom rolling door frame 6' x 6'-8"

Hardware for 2 right panels

Eclipse

Folding Door Systems

Hardware / Integrated Folding Doors / Screens / Shades

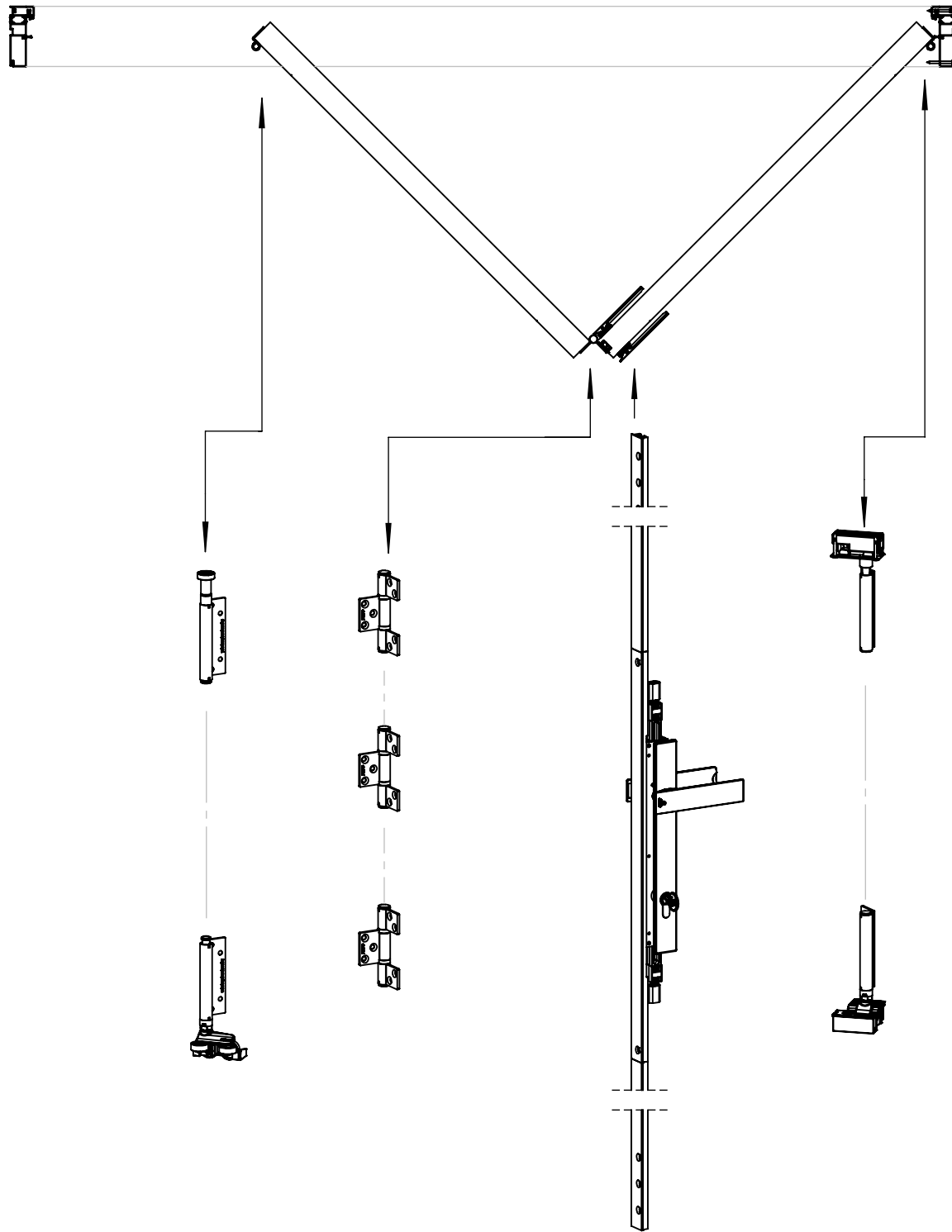

End carrier set
Left

Straight hinge set

TwinPoint Gen2
Left

Pivot set
Right

Bottom rolling door frame 6' x 6'-8"

Frame machining details

Eclipse

Folding Door Systems

Hardware / Integrated Folding Doors / Screens / Shades

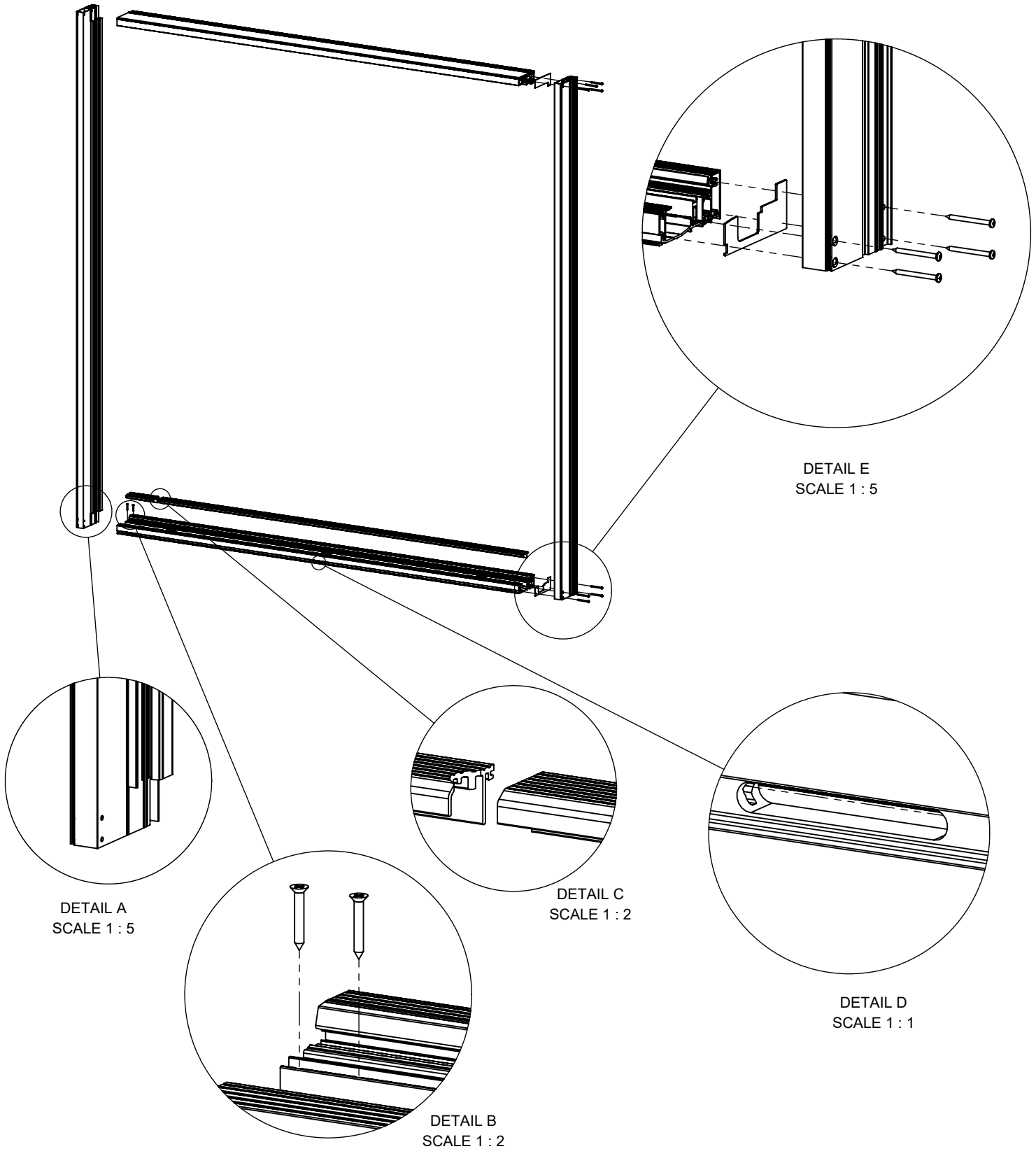

Bottom rolling door frame 6' x 6'-8"

Frame machining details

Eclipse

Folding Door Systems

Hardware / Integrated Folding Doors / Screens / Shades

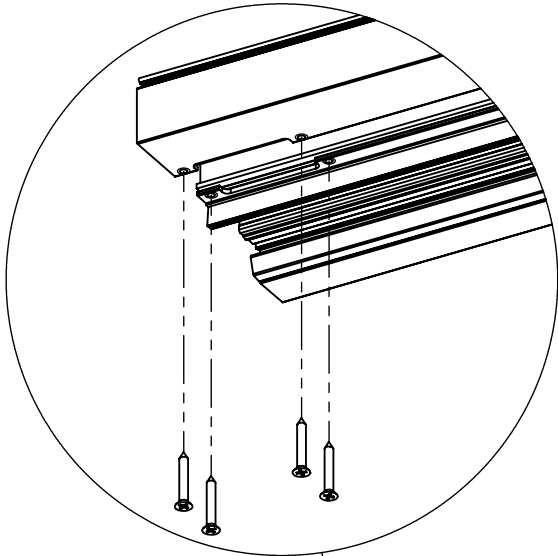

DETAIL F
SCALE 1 : 3

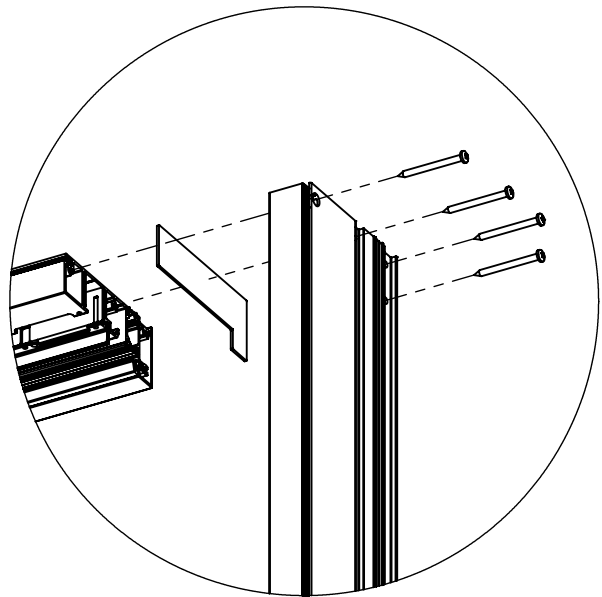

DETAIL G
SCALE 1 : 5

